

# 1925 Biceps Curl

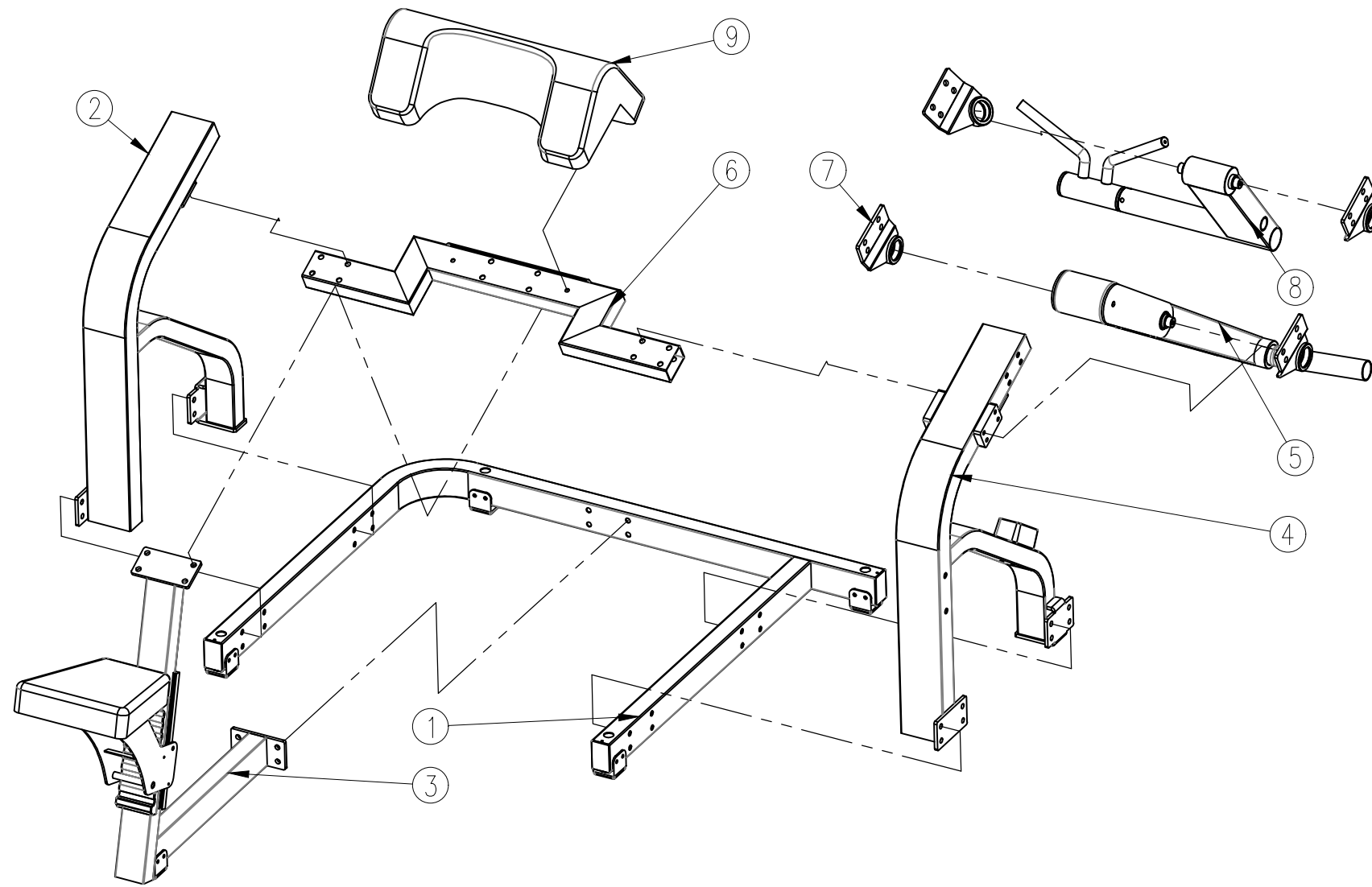

| Serijski broj | Naziv dela                           | Kol. |
|---------------|--------------------------------------|------|
| 1             | Donji ram – sklop                    | 1    |
| 2             | Levi bočni sklop                     | 1    |
| 3             | Sklop nosača sedišta                 | 1    |
| 4             | Desni bočni sklop                    | 1    |
| 5             | Pokretna ruka – sklop                | 1    |
| 6             | Nosač jastuka za ruke – sklop        | 1    |
| 7             | Sklop ležaja osovine (upareni sklop) | 4    |
| 8             | Sklop ručki                          | 1    |
| 9             | Jastuk                               | 1    |

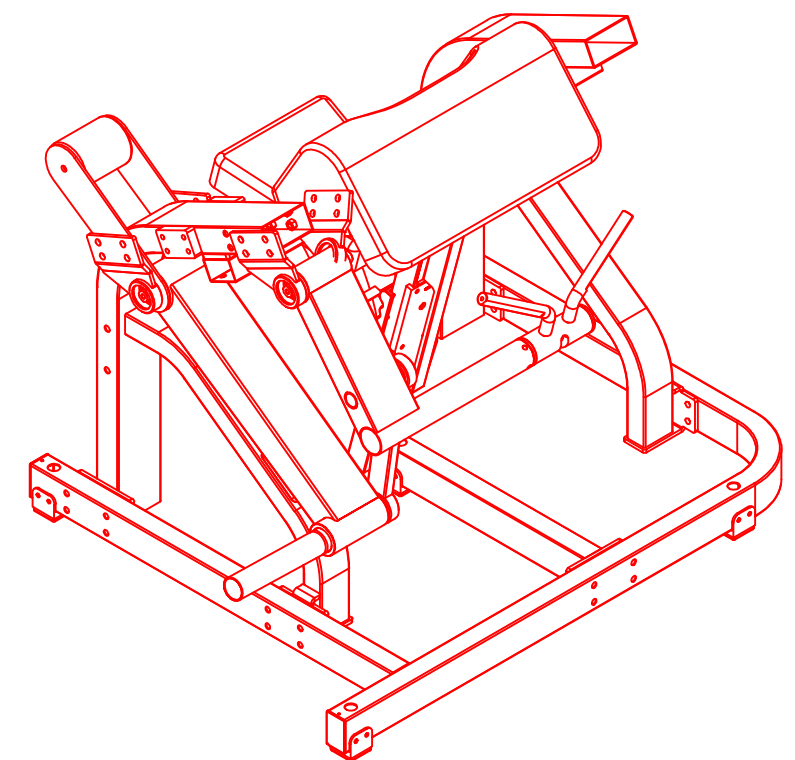

1925